

HYGRODYNAMICS

PORTABLE DEW POINT MONITOR

MODEL 8098
8098-230VAC

TABLE OF CONTENTS

SPECIFICATIONS	2
PRINCIPLE OF OPERATION	2
INSTALLATION	3
Positive Pressure Sampling	3
Enclosure Mounting	3
Sample Air Connection	3
Remote Alarm Connection	3
Recorder Output Connection	3
OPERATION	4
MAINTENANCE	4
Dry Down Test	4
Sensor Replacement Procedure	4
Alarm Set Point Adjustment	5
°F to °C Display Change	5
Electronic Test	5
SPARE PARTS	5
WARRANTY	6

DIAGRAMS

GENERAL ARRANGEMENT (DWG # 8098)
WIRING DIAGRAM (DWG # 6392NWD)

NEWPORT SCIENTIFIC, INC.
8246-E SANDY COURT
JESSUP, MARYLAND 20794-9632
PHONE (301)498-6700 FAX (301) 490-2313 E-MAIL NEWPORT888@AOL.COM

**DEW POINT MONITOR
MODEL 8098**

SPECIFICATIONS

Dew Point Range:	-40°F to +15 °F (-40° C to -9° C)
Sensor Part #:	1205DM
Accuracy:	±2 °F
Max. Pressure:	+7 psig
Alarm Set Point:	-10F (-23C) (Adjustable, see Maintenance)
Alarm Indication:	Red Light and Audible Alarm With Silencer Switch.
Alarm Output:	Normally Open and Normally Closed Dry Contacts Rated @ 5AMP, 115VAC.
Recorder Output:	4-20mA scaled as -40° F to +70° F. Jumper selectable 0-5V. $\text{mA} = \frac{\text{DP} + 67.5}{6.875} \quad \text{or} \quad \text{V} = \frac{\text{DP} + 40}{22}$ -40 = 4mA or 0V 70 = 20 mA or 5V
Power Requirements:	115VAC ±10%, 50/60Hz, 0.1 AMPS (230V available)
Pump Specifications:	Flow: 2.5 L/min (0.08 SCFM) Vacuum: 6.8" of Hg Pressure: 3.2 psi (All pump specifications are nominal)
Enclosure:	Lexan NEMA-12 Electrical Box, CSA Approved. Wall Mountable or Portable With Removable Front Cover.
Dimensions:	10½" x 8½" x 6"
Net Weight:	8.5 lbs.

PRINCIPLE OF OPERATION

The Dew Point Monitor is an instrument used to check the operation of a desiccant dryer. The monitor samples process air from the dryer into an internal manifold containing a **HYGROSENSOR** which varies its electrical resistance inversely proportional to the dew point of the sampled air.

The **HYGROSENSOR** is measured by an internal circuit which drives the LED display and illuminates either the red or green light. Air is sampled via tubing through an in line filter and through a copper cooling coil. The cooling coil enables dew point monitoring at elevated temperatures (500F max.). A

green light indicates a properly functioning desiccant dryer.

INSTALLATION

The Dew Point Monitor can be used to sample air that is at a pressure between -3 and +7 psig. This pressure range is typical of plastic hopper drying systems. Air up to 500 °F (drybulb) can be sampled.

Positive Pressure Sampling (ABOVE 7 PSIG) -Call Newport Scientific, Inc. for Dewpoint Monitor Model # 8094.

Enclosure Mounting

1. Remove the screws that hold the brackets on the backside of the unit.
2. Re-install brackets so the flanges extend beyond the top and bottom of the unit.
3. Mount the unit to a chosen location with bolts.

Sample Air Connection

Choose a sampling location in your system where you wish to measure dew point. Insert one end of the clear tubing into your sample location and connect the other end to the copper coil.

Turn power on and allow reading to stabilize. This may take 10-20 minutes when Dew Point Monitor is first installed. After the unit has operated a while, it will respond to changes in dew point in about 5 minutes. Faster response can be obtained by shortening the length of sample tubing as your application allows.

NOTE: The length of copper tubing should not be shortened.

Remote Alarm Connection (TB1)

Refer to the wiring diagram for details on alarm connection.

1. Route wires through the liquid tight fitting on the side of the dew point monitor.
2. Connect wires to terminal block on PC Board.
 - 4 & 5 are normally closed. They make continuity when the dew point is below set point (green light).
 - 5 & 6 are normally open. They make continuity when the dew point is above set point (red light).
3. Gently tighten the liquid tight fitting.

Recorder Output Connection (TB3)

1. Route wires through the liquid tight fitting on the side of the dew point monitor.
2. For 4-20mA connect wires to terminals 2 & 3 of TB3 of the PC Board. Terminals 1 & 2 for 0-5V.
3. Gently tighten the liquid tight fitting.

-40°F=0V or 4mA; +15°F=2.5V or 12mA.

OPERATION

If the unit is sampling process air after it leaves a drying hopper filled with hygroscopic material, initially high dew points will be encountered. As the moisture is purged out of the material the dew point decreases. For most thermoplastic resins -10°F dew point is an acceptable condition for the process air leaving the hopper.

If the Dew Point Monitor indicates a High Alarm, the following conditions should be considered:

1. There is a leak in the dryer system or sampling line.
2. The dryer is overloaded by excessively wet material.
3. The dryer has a mechanical or electrical failure.
4. The Dew Point Monitor has failed (see calibration and maintenance instructions).

MAINTENANCE

Field calibration of the Hygrosensor is impractical. Therefore it is suggested that a spare sensor be kept on hand to serve as a quick accuracy check.

Dry Down Test

Verification of the Dew Point Monitor's ability to read down to -40°F can be performed by the following steps.

1. Connect one end of the desiccant cartridge to the sample air inlet tubing and the other end to the pump vent tubing.
2. Turn the power on and allow 10 – 20 minutes for the unit to read -40°F ($\pm 2^\circ\text{F}$). If Dew Point Monitor doesn't read properly, check for proper vacuum (3" of Hg minimum), replace sensor, perform Electronic Test, or contact Newport Scientific for factory service.

The desiccant in the tube should be blue. If the color has faded, the desiccant should be regenerated by pouring the desiccant into a suitable container and then heated in a 350°F oven for one hour. This can also be done in a microwave oven for 10 minutes set on high. Allow desiccant to cool and replace back in tube.

Sensor Replacement Procedure

Replacement of the sensor is recommended on a **YEARLY** basis.

**** Remove power to the Dew Point Monitor before servicing.**

1. Remove the panel from instrument case.
2. Disconnect the sensor cable from the manifold.
3. Remove the hex nut and slide the sensor and socket out of the manifold. Remove old desiccant capsule from manifold if present.
4. If your new sensor is packaged with a desiccant capsule, drop it into the manifold.
5. Remove old sensor from socket and press the new sensor into the socket. Then slide the sensor and socket into the manifold.

6. Replace and hand-tighten the hex nut.
7. Install panel in instrument case.

Alarm Set Point Adjustment

Locate the display function switch (S1) on PC Board. **Note that only one position of this switch should be ON at a time.**

1. To view and adjust relay #1 setpoint, turn the #1 position of SI OFF and the SET1 position #2 ON. Turn the SET1 of P2 near the switch to the desired setpoint.
2. When finished adjusting the setpoint, return S1 to the default operating mode by turning OPER position ON and all others OFF.
3. A small red LED near the potentiometer P2 indicates when an alarm is occurring.

°F. TO °C. Display Change

To change the digital display to °C, use needle nose pliers and move jumpers J6 and J7 to the C position on PC Board.

Electronic Test Procedure

This procedure checks the operation of the circuit. Perform this procedure if display does not respond to the DRY-DOWN TEST described earlier and if the electronics are suspect.

WARNING

THE FOLLOWING PROCEDURE IS PERFORMED WITH POWER APPLIED. TO PREVENT SHOCK, DO NOT TOUCH ANY TERMINALS INSIDE THE DEW POINT MONITOR.

1. Remove the front cover and disconnect the brown sensor cable from the sensor manifold.
2. Connect the Dew Point monitor to power and turn it on. With sensor cable disconnected, the Dew Point Monitor should read $-40^{\circ}\text{F} \pm 2^{\circ}\text{F}$.
3. Place a jumper across the sensor cable. The Dew point Monitor should read $+15^{\circ}\text{F} \pm 2^{\circ}\text{F}$.

If display fails to read these values, contact Newport Scientific for factory service.

SPARE PARTS

6245-----	Desiccant Tube
1205DM-----	HYGROSENSOR
3305005 -----	Filter

HYGRODYNAMICS

LIMITED WARRANTY

NEWPORT SCIENTIFIC, INC. warrants that all equipment manufactured by NSI shall be free from defects in material and workmanship which might impair its usefulness. SELLER DOES NOT WARRANT THAT THE EQUIPMENT IS FIT FOR ANY PARTICULAR USE. THERE ARE NO WARRANTIES WHICH EXTEND BEYOND THE DESCRIPTION ON THE FACE HEREOF; the obligation under this warranty is limited to repairing or replacing, at Seller's factory, any defective parts which, when returned by the buyer, **TRANSPORTATION PREPAID**, examination discloses to have been factory defective. The time limit of this warranty is ONE YEAR from date of shipment of new equipment, SIX MONTHS from date of shipment of Hygrodynamics Wide-Range Sensors and THREE MONTHS from date of shipment of Hygrodynamics Narrow-Range Sensors and repaired equipment. THIS WARRANTY IS EXPRESSLY IN LIEU OF OTHER WARRANTIES. Seller shall not be held liable for any special, indirect, consequential damages arising out of this warranty or any breach thereof, of any defect in or failure or malfunction of the equipment and materials are further subject to tolerances and variations consistent with usages of trade. This warranty shall run in favor only of the purchaser from Seller and may not be passed on or represented on behalf of Seller to any subsequent purchaser.

WARRANTIES: OTHER PRODUCTS

NEWPORT SCIENTIFIC, INC. makes no express or implied warranty as to items, which are the products of other manufacturers. Seller shall use its best efforts to obtain from the manufacturer, in accordance with its customary practice, the repair or replacement of such products may prove defective in workmanship or material. The foregoing states the entire liability in respect to such products, except as an authorized executive of the corporation may otherwise agree in writing.

In the case of special equipment or modifications to standard equipment manufactured at the request of the buyer, under buyer-approved specifications, buyer will indemnify Seller against the risk damages due to patent infringement.

REVISIONS

A (SAMPLE AIR OUT) WAS LOCATED ON RIGHT SIDE 6/5/00

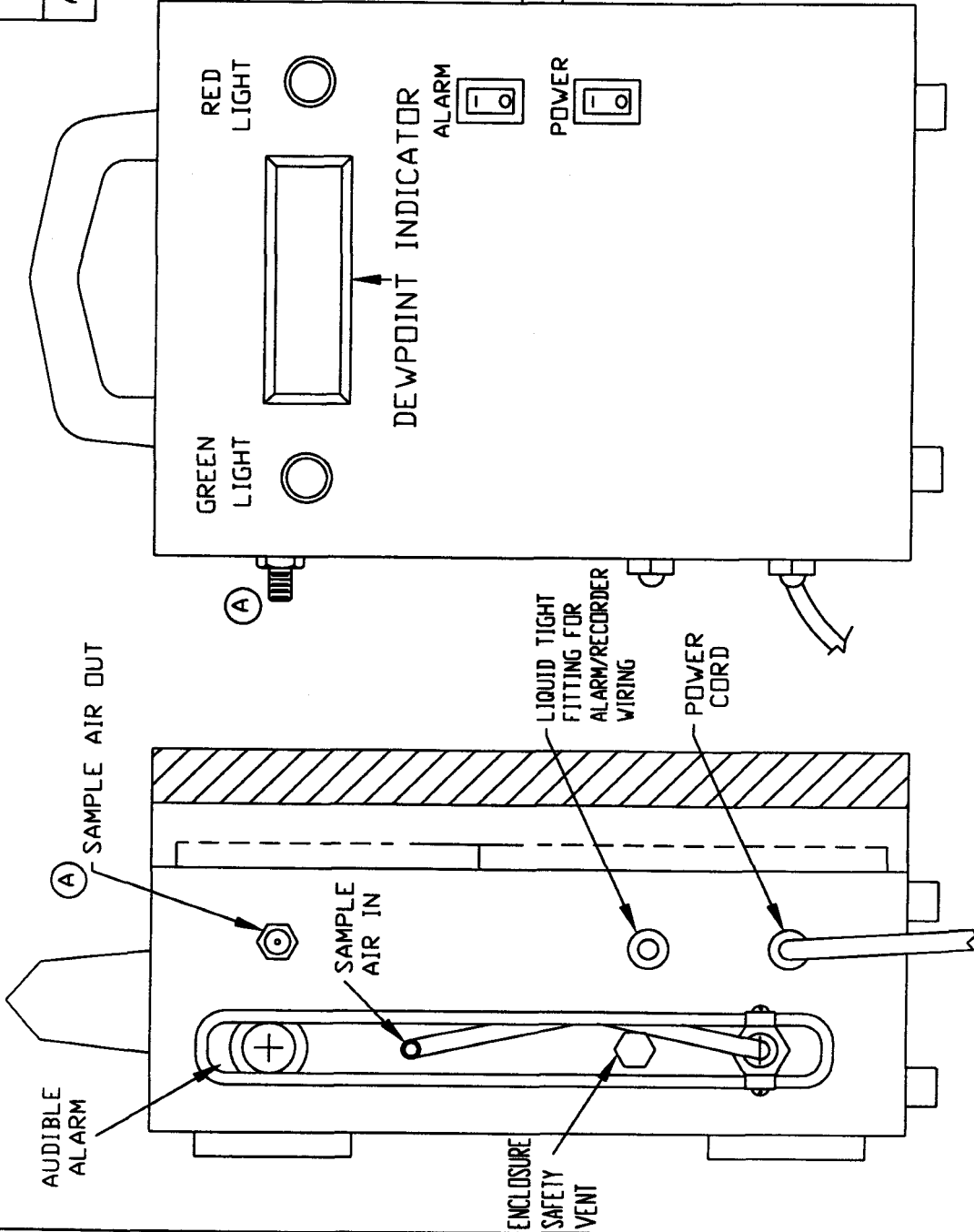

NOTE: 8098 HAS COPPER COIL AT SAMPLE AIR INPUT.

UNLESS OTHERWISE SPECIFIED DIMENSIONS ARE IN INCHES

TOLERANCES:
 FRACTIONS ±
 DECIMALS ±
 ANGLES ±

REMOVE ALL BURRS AND SHARP EDGES

DO NOT SCALE THIS DRAWING

BY	NAME	DATE	FINISH:
PREPARED			
CHECKED			
ENGR/DSGN			
APPROVED			
MATERIAL			

PROPRIETARY
 This document is issued in strict confidence on condition that it is not copied, reprinted, or disclosed to a third party, wholly or in part, without written consent of Newport Scientific, Inc.



TITLE
 GENERAL ARRANGEMENT
 DEW POINT MONITOR

CODE IDENT. NO. 8098
 PART NO. 8098
 DRAWING NO. 8098

SCALE A
 WEIGHT
 SHEET 1 OF 1

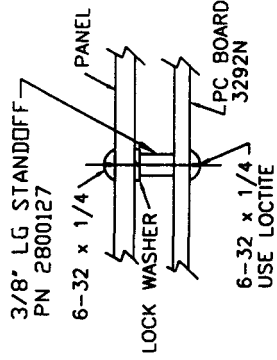
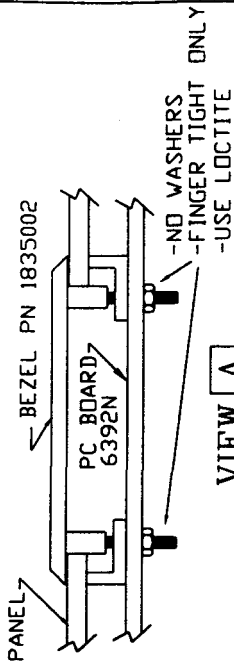

THESE 2 HOLES NOT REQ'D
* IF BEZEL 1835002 IS USED

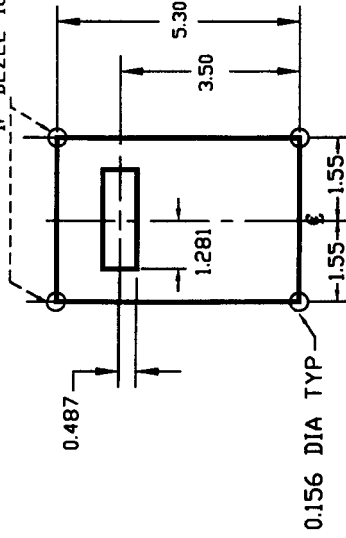

RECOMMENDED PANEL CUT-OUT

GREEN LIGHT

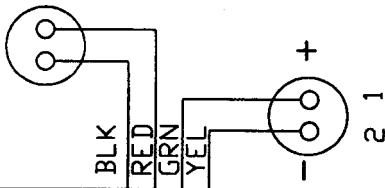

RECORDER OUTPUT JACK

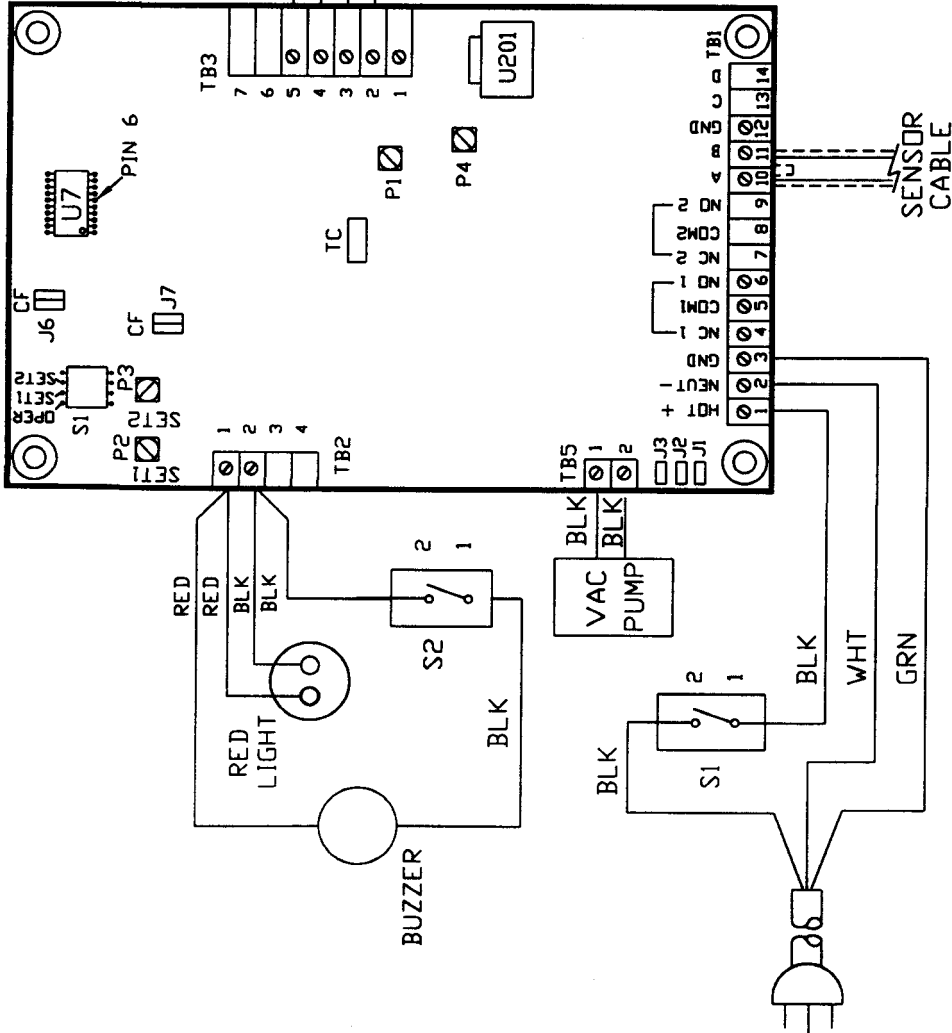

UNLESS OTHERWISE SPECIFIED DIMENSIONS ARE IN INCHES TOLERANCES:

FRACTIONS ±
DECIMALS ±
ANGLES ±

REMOVE ALL BURRS AND SHARP EDGES

DO NOT SCALE THIS DRAWING

BY NAME DATE FINISH:

PREPARED	NAME	DATE	FINISH:
CHECKED			
ENGR/DRSM			
APPROVED			

PROPRIETARY

This document is issued in strict confidence on condition that it is not copied, reprinted, or disclosed to a third party, wholly or in part, without written consent of Newport Scientific Inc.



MOUNTING & WIRING FOR 6392N & 6392N2 D/P BOARD

SCALE WEIGHT PART NO. 59505 DRAWING NO. 6392NVD

SHEET OF

NOTE: RED & GREEN LIGHTS ARE OPTIONAL.